

Malmo TV Table



Please read these instructions very carefully before you begin to ensure that your Futon Company Malmo TV Table will give you many years of satisfaction.

Thank you for buying a Futon Company product.

We are constantly striving to improve everything we do, but occasionally mistakes do occur. In the unlikely event that you find any part missing, please call your nearest Futon Company store and we will arrange for the despatch of an immediate replacement. Please keep all packaging until you have checked every part and assembly of your Futon Company product is complete.

Version: 1

Product Code: T4 MALMO TV

PO 13040

experts in small space living



Part Checklist

Please count and check every component very carefully before you begin

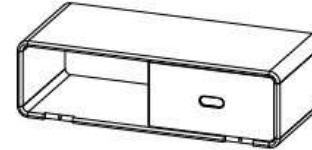

1. Cabinet x 1

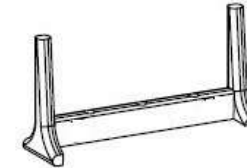

2. Left Leg (L) x 1

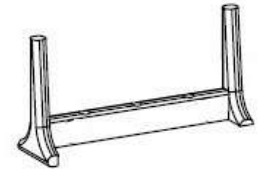

3. Right Leg (R) x 1



Fittings Checklist

Please count and check every component very carefully before you begin



A Allen Key x 1



B Bolt x 6



C Spring Washer x 6

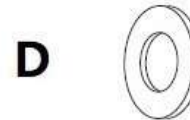

D Flat Washer x 6



E Wood Dowel x 2



F Felt Pad x 4



How to assemble Malmo TV Table

Please follow these instructions carefully

FUTON

C O M P A N Y

Step 1 : Lay the table face down on a clean, flat, soft surface to prevent scratching the top.

Step 2 :

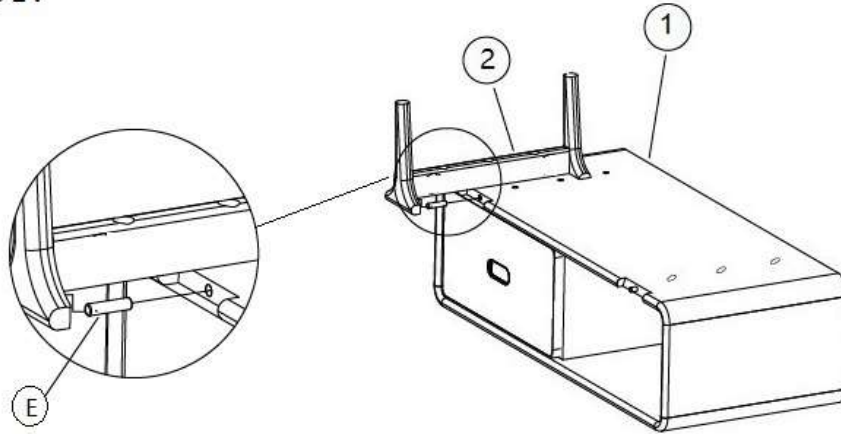

Step 3 :

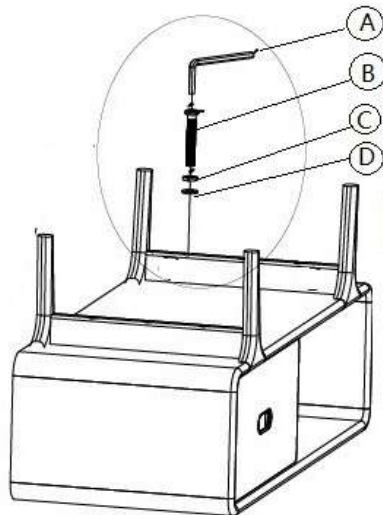

Repeat this step for all 6 bolts.

Step 4 :

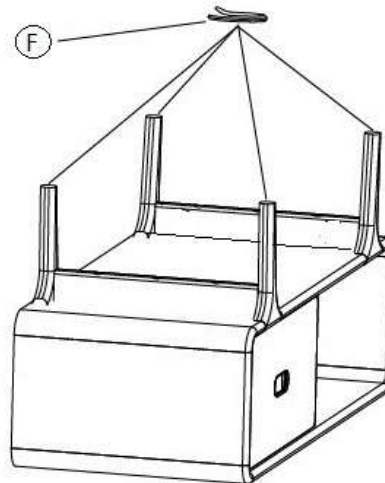

FINISH
Timber may be selected to ensure that the visible surfaces are of a higher grade than unseen surfaces. These unseen areas are not finished to the same standard as visible surfaces.

CARE
To clean your table, wipe with a damp cloth followed by a dry cloth.

IMPORTANT
To ensure maximum performance from this product, we advise that you check and tighten all bolts and screws on a regular basis to avoid damage and strain to parts. Improper use, improper assembly and mishandling may lead to product damage.

DO NOT STAND ON THIS TABLE

GUARANTEE
This instruction leaflet forms part of your guarantee, please retain it. The PO number along with your invoice number will need to be quoted in all correspondence with Futon Company.

Thank you for choosing Futon Company.

