

Assembly Instructions

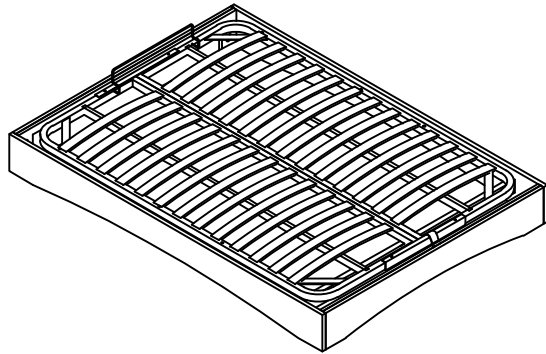

Oak Curve Bed (King)

ROPO no:



PLEASE READ THESE INSTRUCTIONS VERY CAREFULLY BEFORE YOU BEGIN, TO ENSURE THAT YOUR FUTON COMPANY PRODUCT WILL GIVE YOU MANY YEARS OF SATISFACTION

Thank you for buying Futon Company product

We are constantly striving to improve everything we do, but very occasionally mistakes do occur.

In the unlikely event that you find any part missing please call your nearest Futon Company store and we will arrange for the despatch of an immediate replacement.

Please keep all packaging until you have checked every part and assembly of your Futon Company product is complete.

Version number: 1

Product code: BD5 CURVE OAK

Date: 15/03/25

experts in small space living



A. The Lift Mechanism assists in raising the mattress on the base but doesn't lift it for you. It works with various mattress weights and depths.

Maximum lift weight (including mattress & bedding): 80kg for King

B. After installation, lift/pull the base up and down a few times to loosen the system. Gas Springs may be stiff initially or after long periods of inactivity. The mattress must be attached to the base.

C. Use two hands to lift and lower the mattress base, evenly spaced from the centre of Front Board. Avoid pulling down on one side to prevent damage or failure of the base and lift mechanism. Always ensure the mattress is fitted before using the lift mechanism.

CAUTION:

- Children must not operate the lift mechanism or be near the lift base during operation.
- Ensure children and pets stay away from the internal storage base area.
- Keep hands away from the mechanism while operating the base system.
- Do not stand inside the bed or on the internal storage base.
- Avoid overloading the internal storage base.



Parts Checklist

Please count and check every component very carefully before you begin

- ① Back Board x 1
- ② Right Side x 1
- ③ Left Side x 1
- ④ Inside Bar x 1
- ⑤ Front Board x 1
- ⑥ Bed Slats x 1
- ⑦ End Bars x 2
- ⑧ Right lift Mechanisms x 1
- ⑨ Left lift Mechanisms x 1
- ⑩ Gas Spring x 2
- ⑪ Mattress Stay x 1

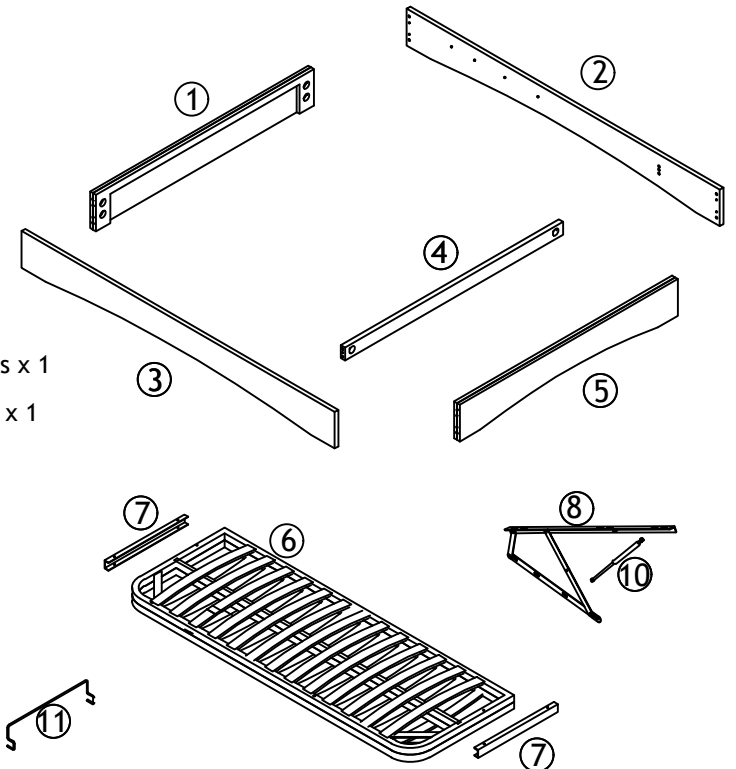



Fittings Checklist

Please count and check every component very carefully before you begin

Box 1 of 2



(a) Wooden Dowel x 12

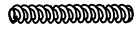

(b) Bolt x 10



(c) Nut x 10



(d) Pressure Plate x 10



(e) Small Spanner $\Phi 10$ x 1



(f) (m8x20)Allen Head Bolt x 8

Box 2 of 2



(g) (m8x45)Allen Head Bolt x 4



(h) (m8x50)Allen Head Bolt x 6



(i) Small Spanner $\Phi 12$ x 1



(j) Small Spanner $\Phi 13$ x 1



(k) Allen Key x 1



(l) Locking Nut x 4



(m) Nut x 10



(n) Strap x 1



How To Assemble Your Bed

Please follow these instructions carefully

To prevent scratching: Lay the parts face down on a clean, flat, soft surface.

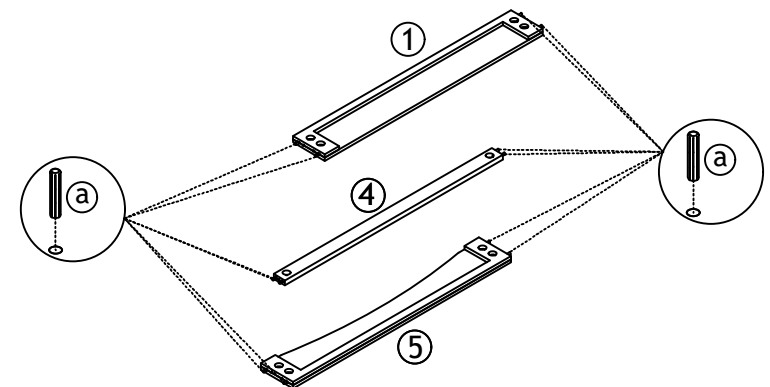
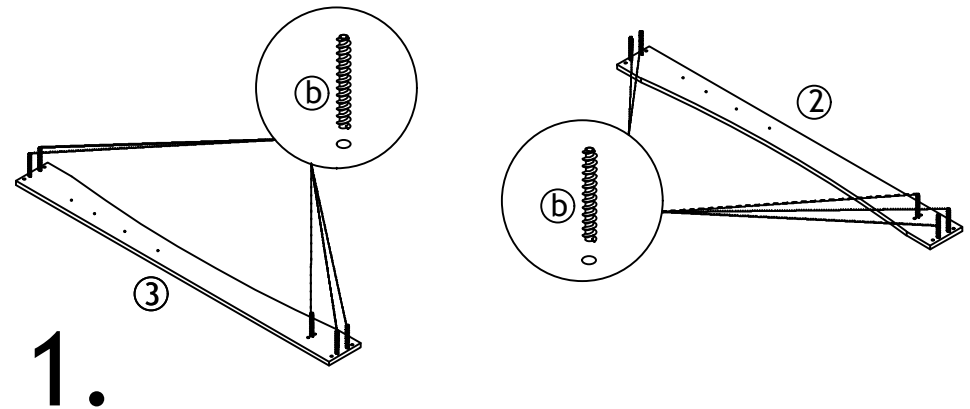



How To Assemble Your Bed

Please follow these instructions carefully

FUTON

C O M P A N Y

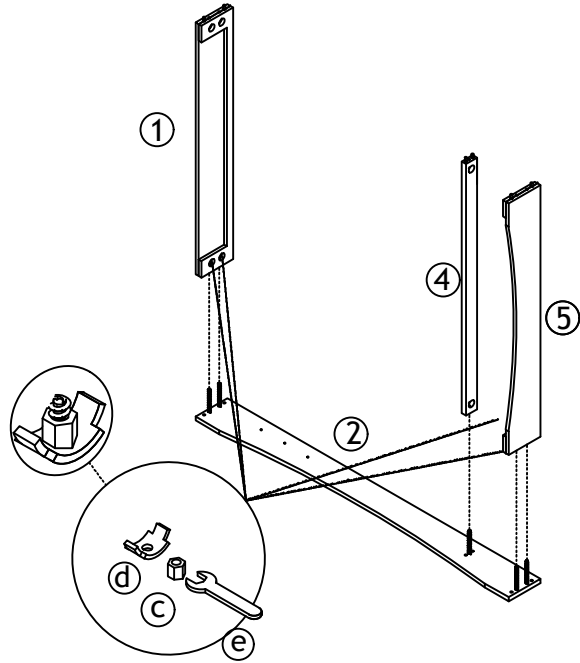

3.

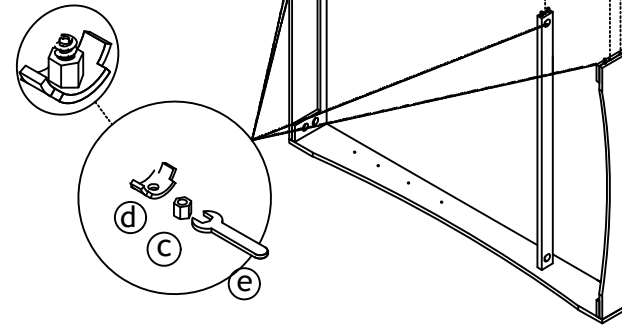

4.

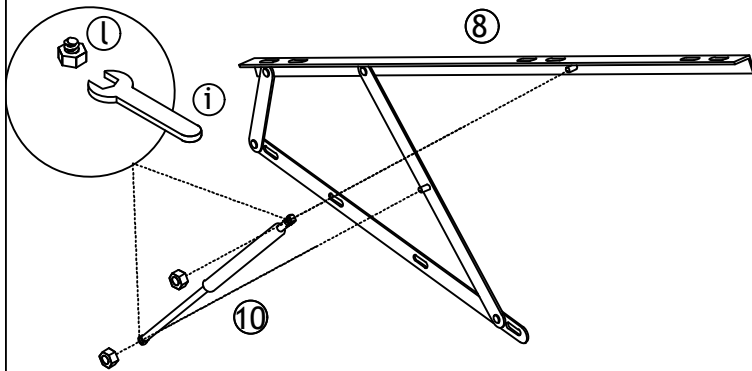

5.

Fully tighten all nuts after attaching the Gas Spring.

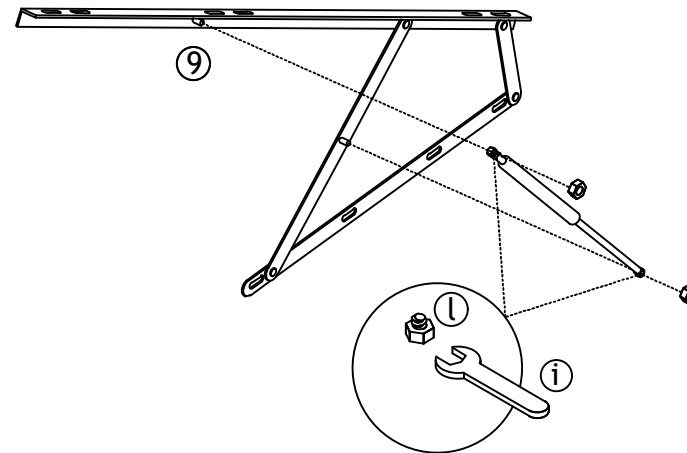
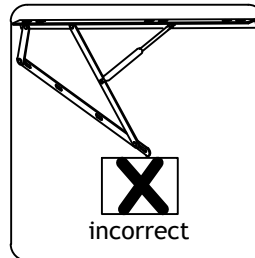
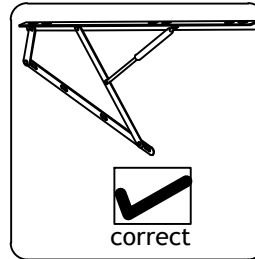

6.

Fully tighten all nuts after attaching the Gas Spring.

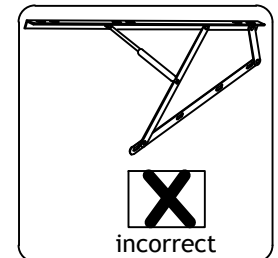
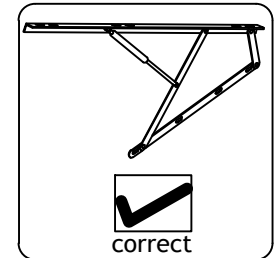



How To Assemble Your Bed

Please follow these instructions carefully

FUTON

C O M P A N Y

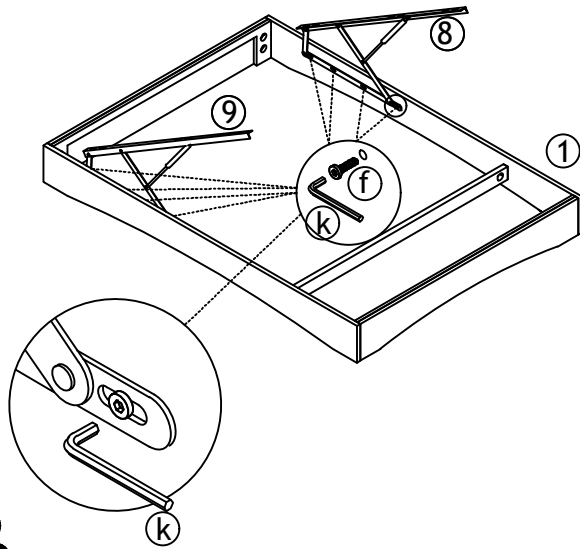

7.

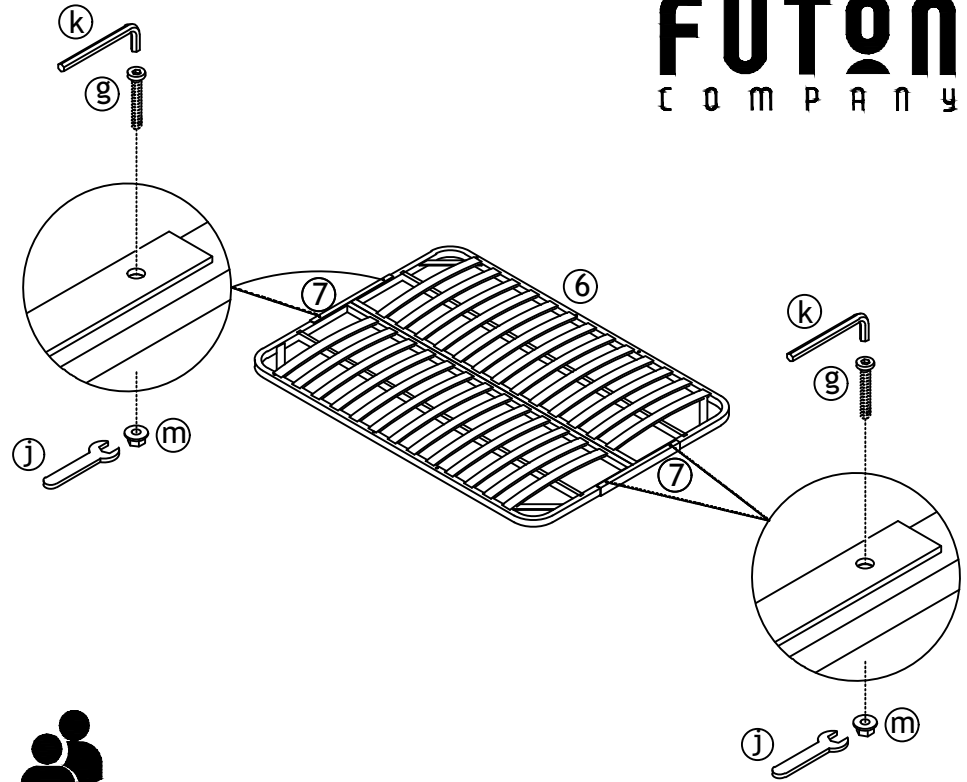

8.

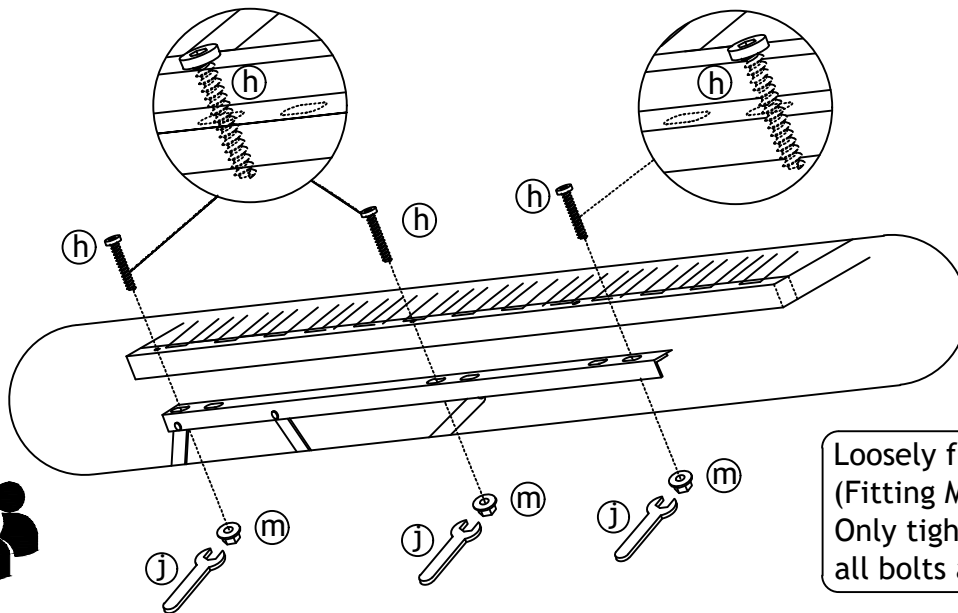

9.

Loosely fit the nut (Fitting M) onto Fitting H. Only tighten fully when all bolts are in place.

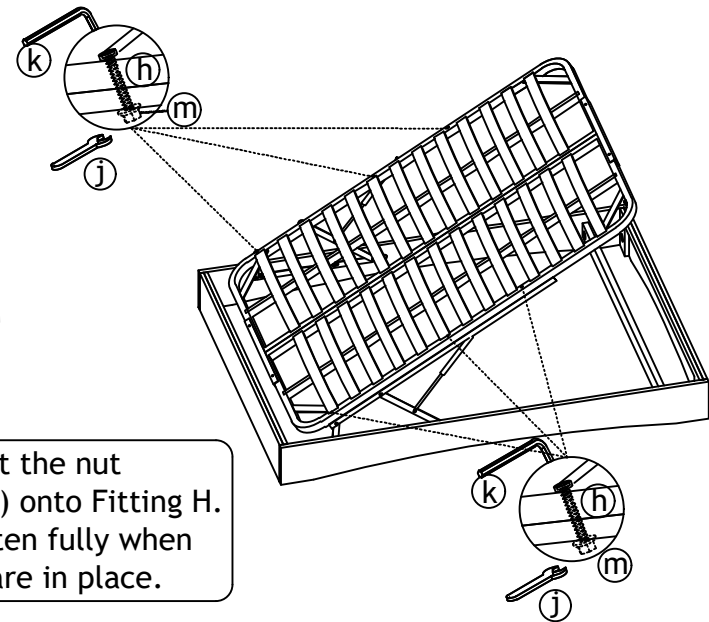

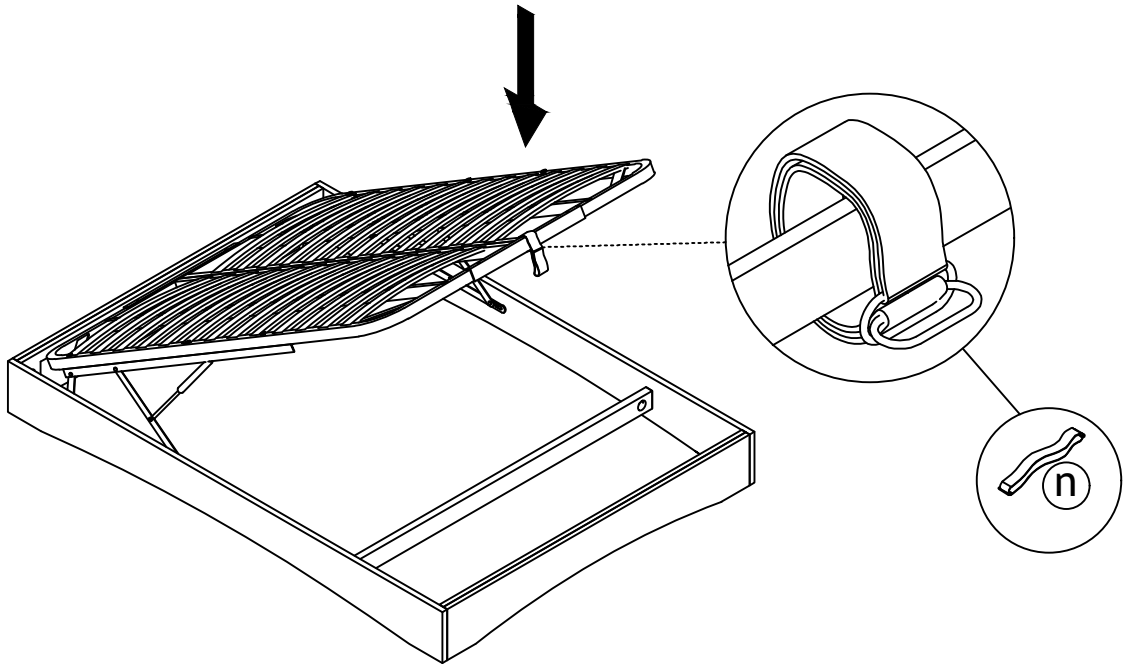

10.

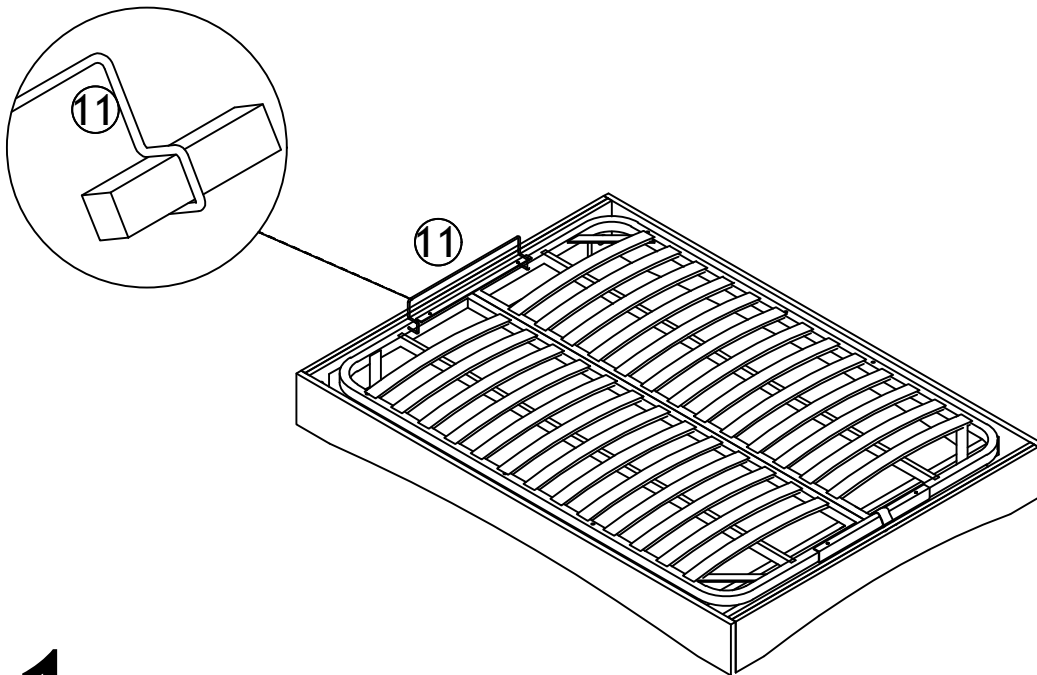

11.



How To Use

Please read carefully

After installation, lift/pull the base up and down a few times to loosen the system. Gas Springs may be stiff initially or after long periods of inactivity. The mattress must be attached to the base.

Use two hands to lift and lower the mattress base, evenly spaced from the centre of Front Board. Avoid pulling down on one side to prevent damage or failure of the base and lift mechanism. Always ensure the mattress is fitted before using the lift mechanism.

FINISH

Your Bed is made from solid Oak and Metal.

CARE

To clean your Bed, wipe with a damp cloth followed by a dry cloth.

IMPORTANT

To ensure maximum performance from this product, we advise that you check and tighten all bolts and screws on a regular basis to avoid damage and strain to parts.

GUARANTEE

This instruction leaflet forms part of your guarantee. Please retain it. The ROPO number along with your invoice number will need to be quoted in all correspondence with Futon Company.

Thank you for choosing Futon Company.

