

SB2 BELLA V2-PO13041

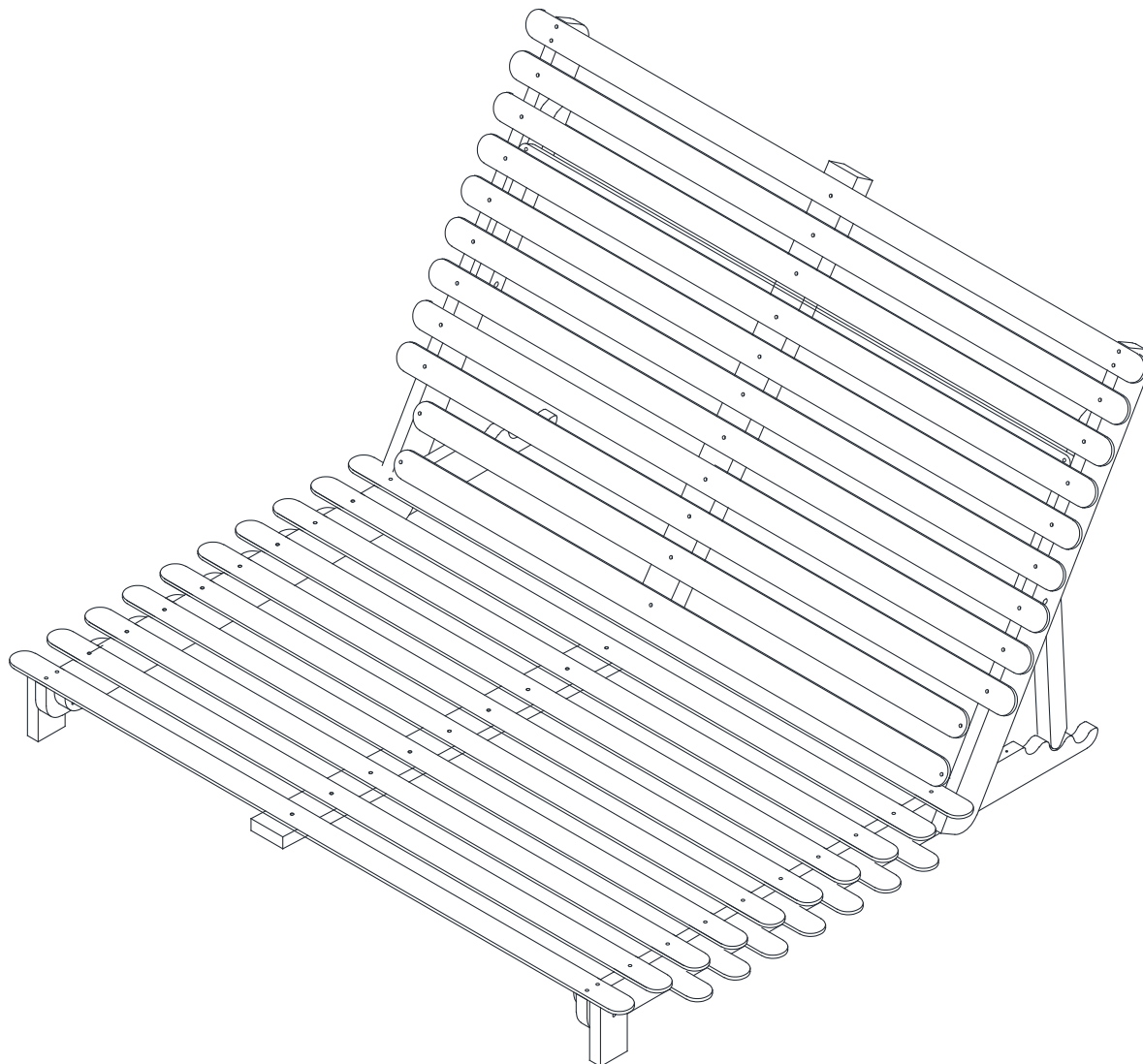

Thank you for purchasing this Futon Company product. Please read the instructions carefully before assembly.

Please check the pack contents before starting to assemble this product. A full checklist of components is given in this leaflet. If any components are missing, please contact your nearest Futon Company store and we will arrange despatch of an immediate replacement.

Parts Checklist

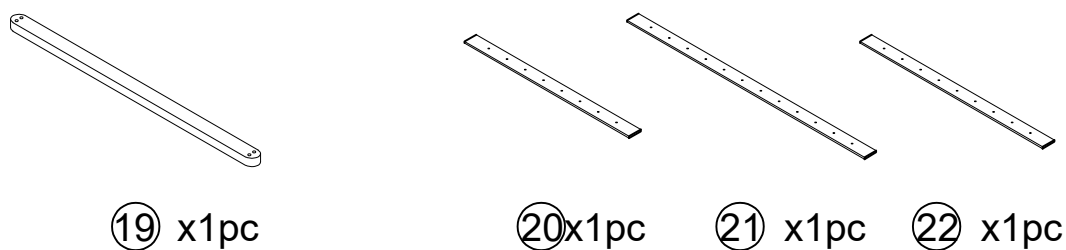
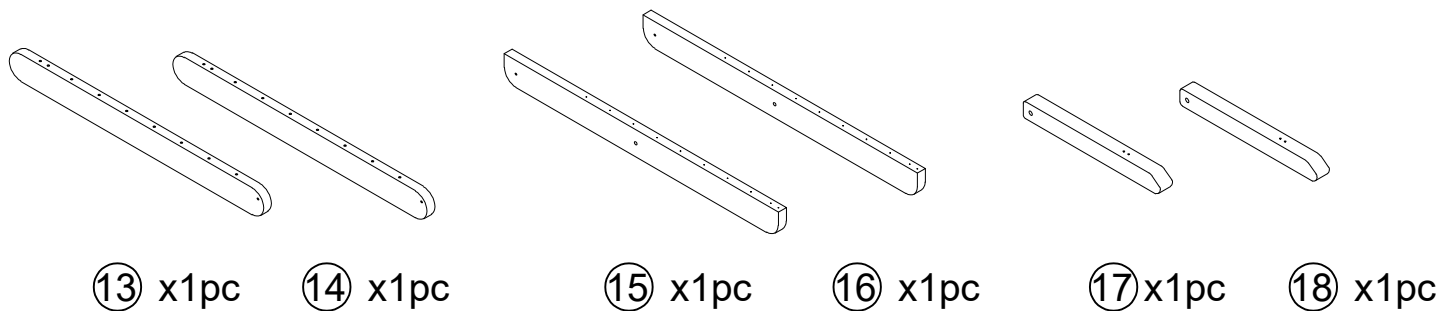
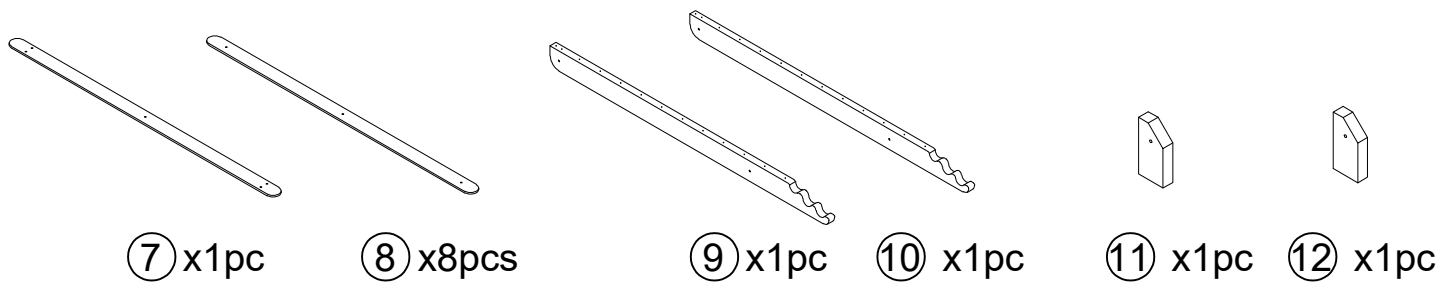
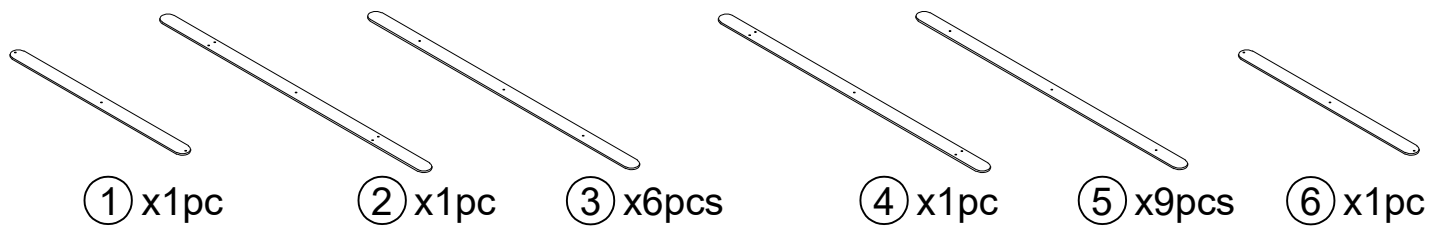

Fittings Checklist

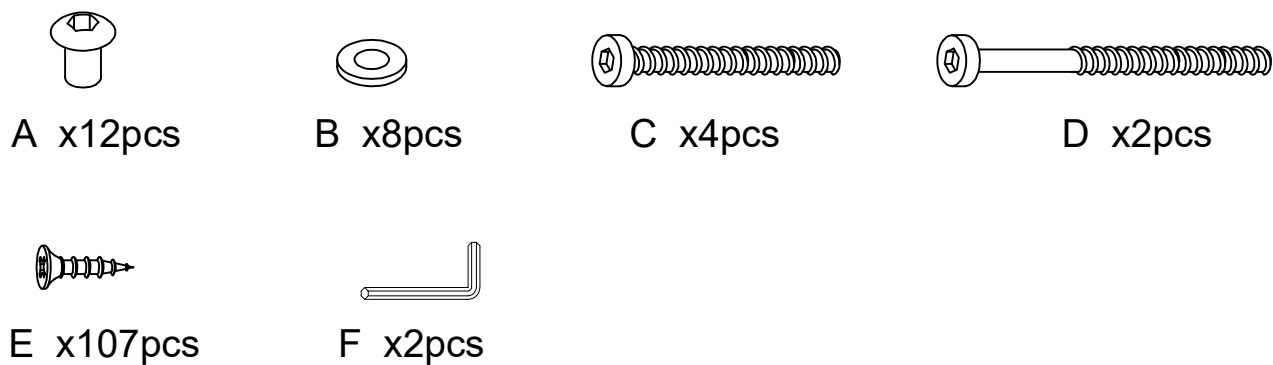

1.

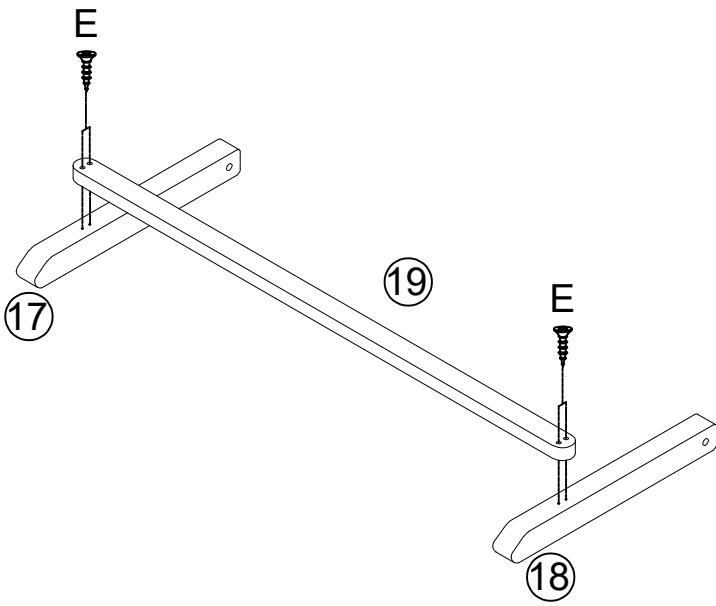

2.

Do not fully tighten fittings when assembling sub frame.
Overtightening fittings before slats are screwed down can lead to mis-alignment of components.

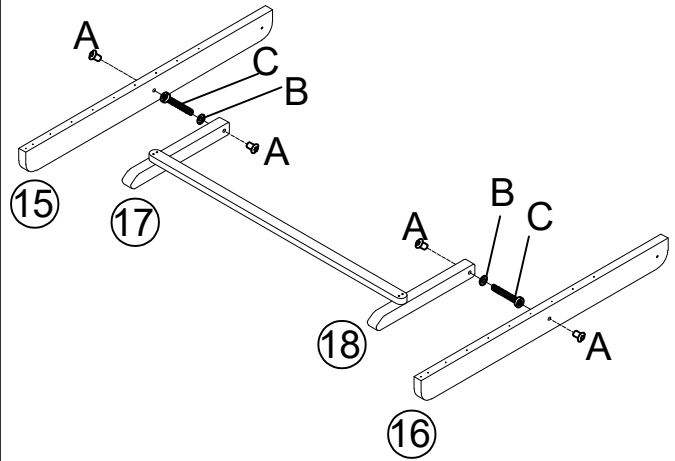

3.

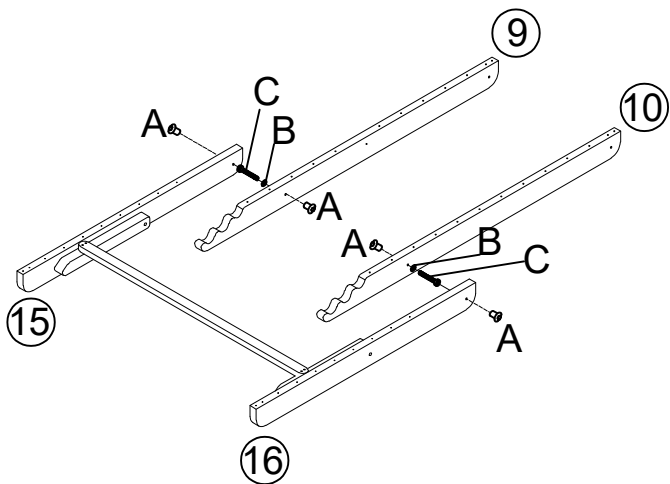

4.

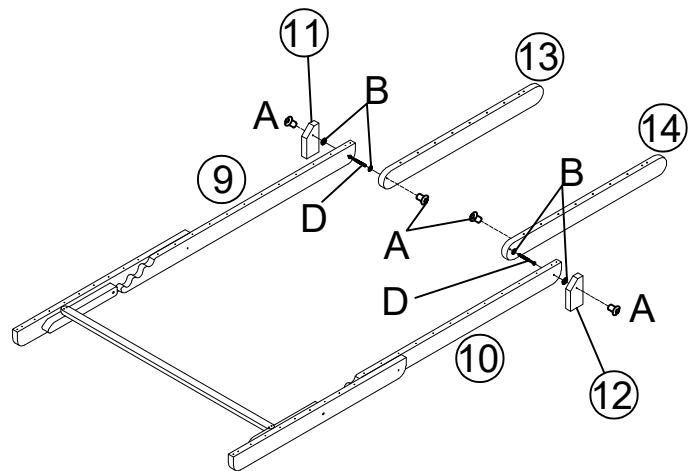

5.

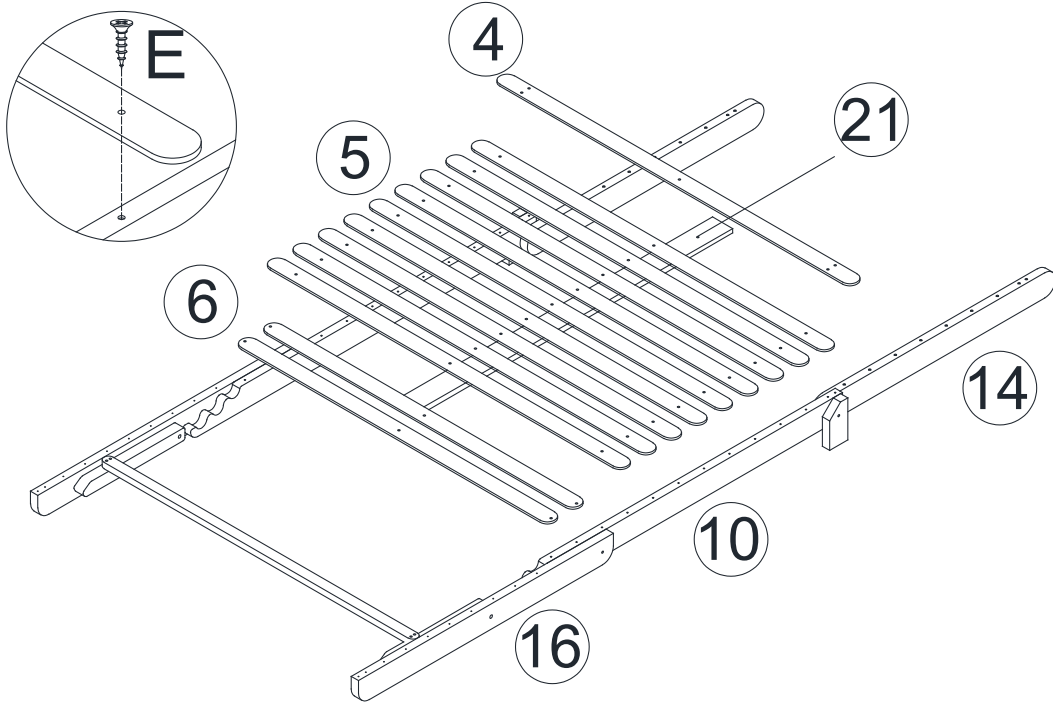

Using Fitting E, screw slat numbers 4 and both of slats 6 into place first. Then lay all of slats part 5 into position before screwing down.

6.

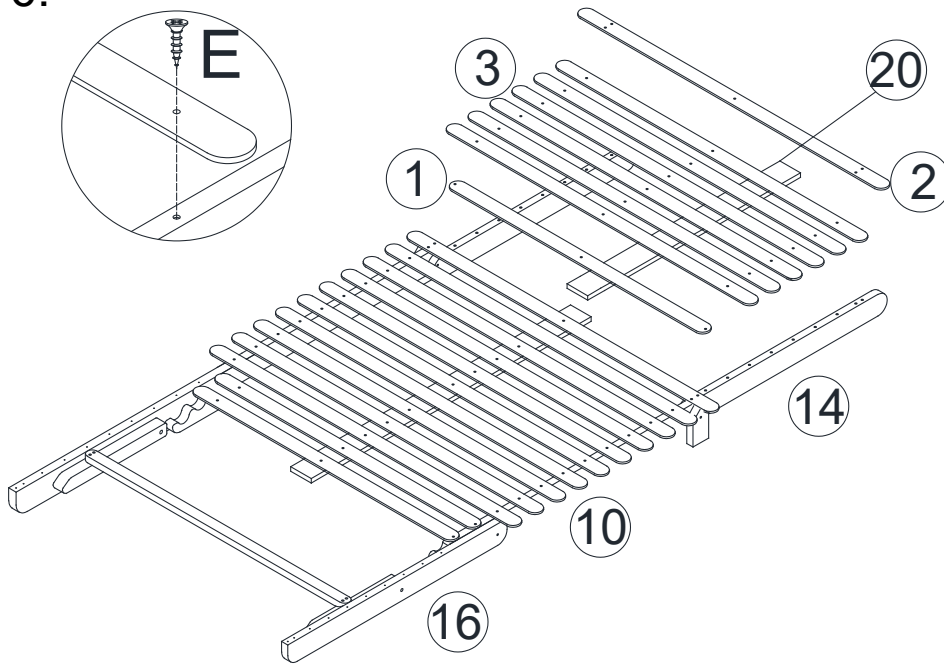

Using Fitting E, screw slat numbers 1 and 2 into place first. Then lay all of slats part 3 into position before screwing down.

7.

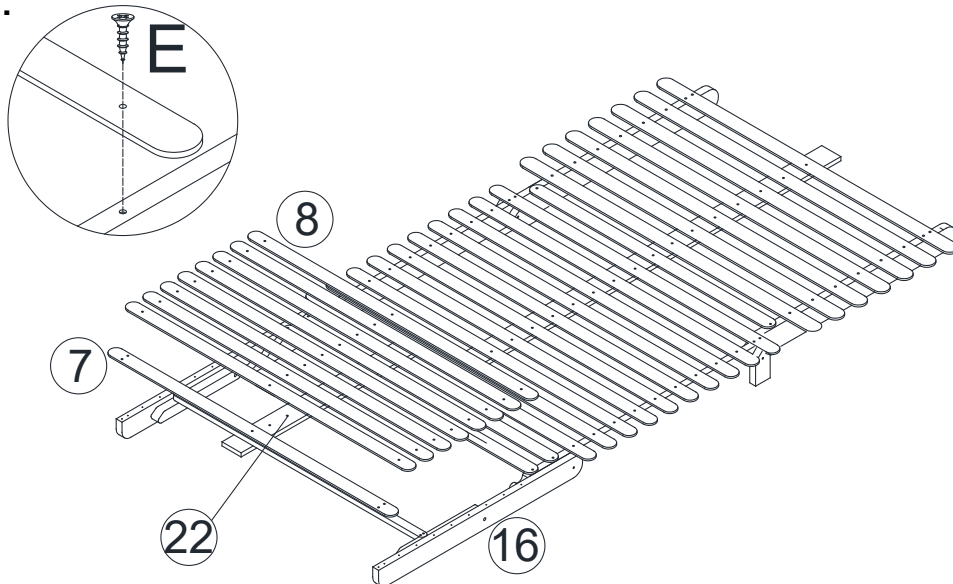

Using Fitting E, screw slat 7 and one slat 8 into place first before laying out and screwing down the remaining slats.

8.

Fully tighten Fittings A,B,C & D

