

# SB1 TITCH V2-PO13041

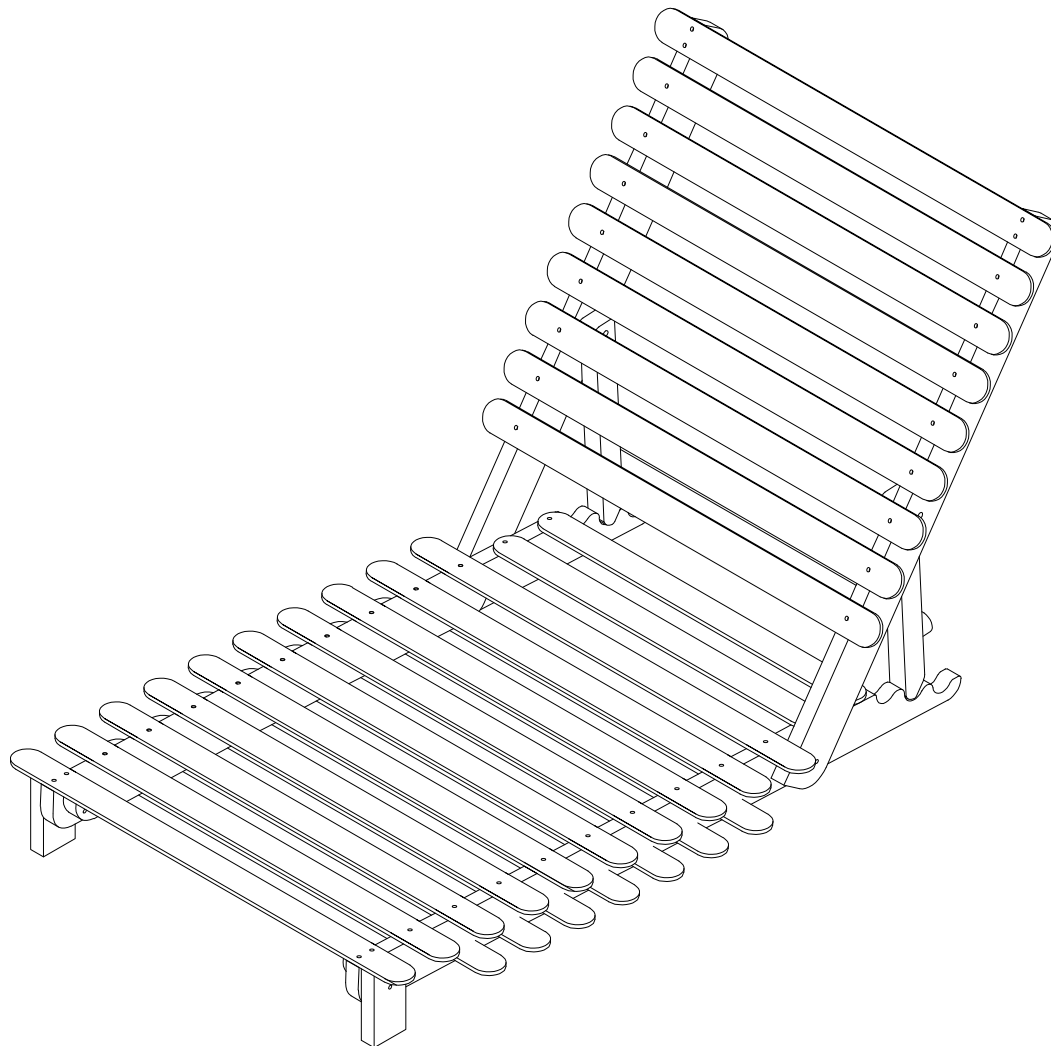

Thank you for purchasing this Futon Company product. Please read the instructions carefully before assembly.

Please check the pack contents before starting to assemble this product. A full checklist of components is given in this leaflet. If any components are missing, please contact your nearest Futon Company store and we will arrange despatch of an immediate replacement.

# Parts Checklist

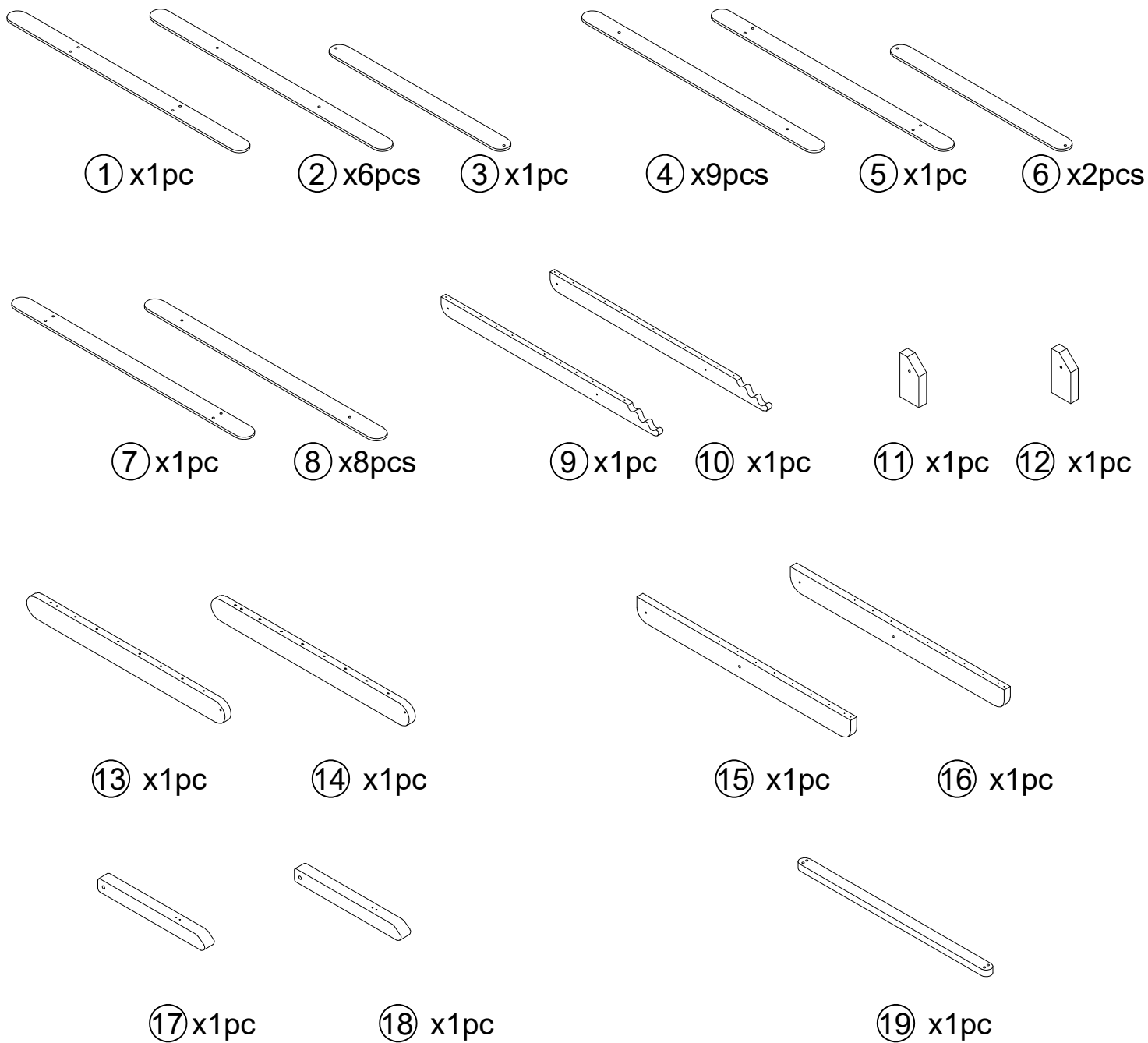

# Fittings Checklist

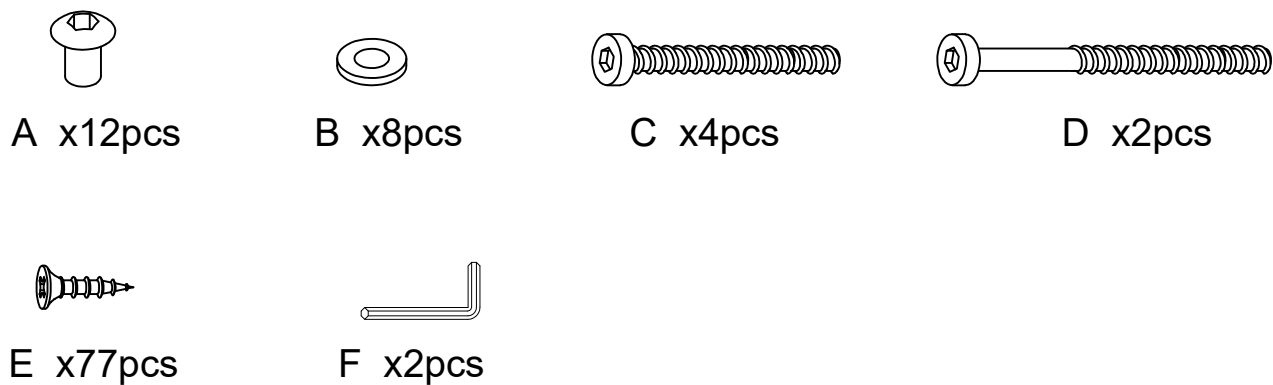

1.

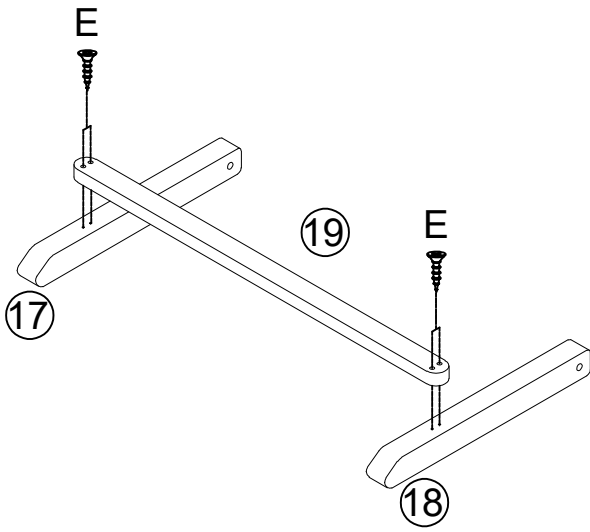

2.

Do not fully tighten fittings when assembling sub frame. Overtightening fittings before slats are screwed down can lead to mis-alignment of components.

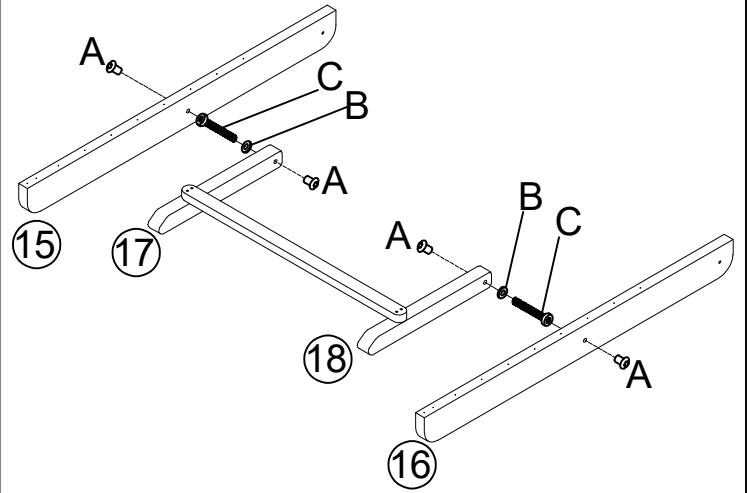

3.

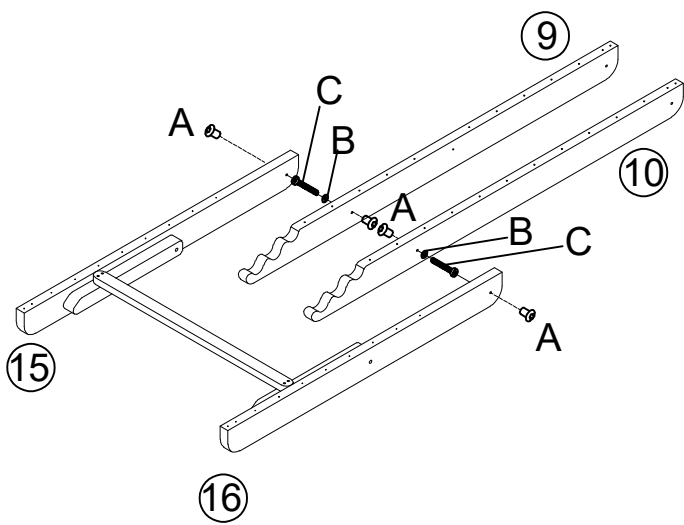

4.

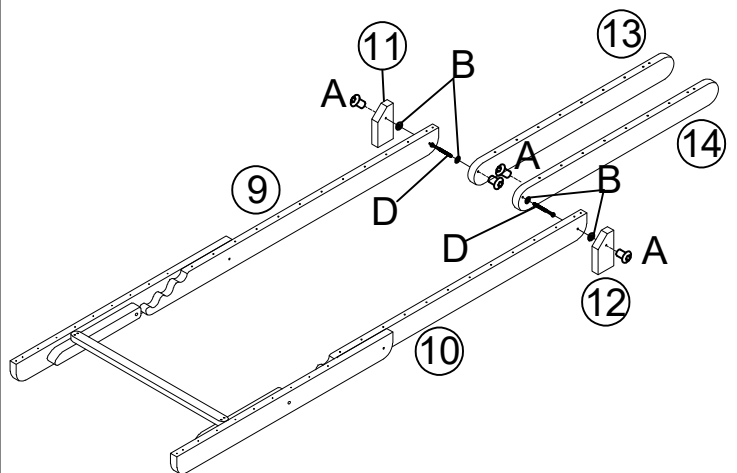

5.

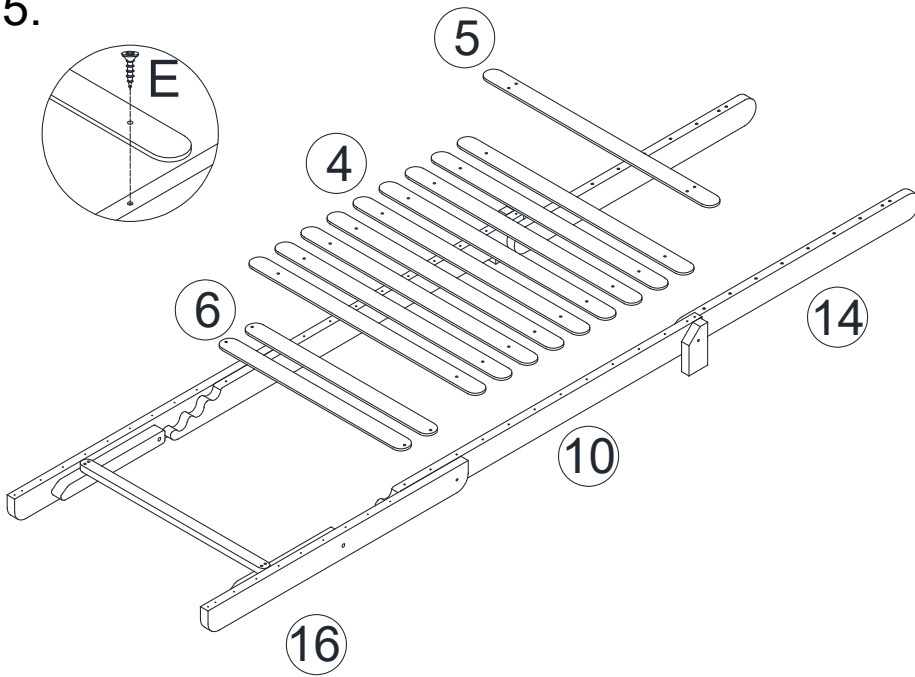

Using Fitting E, screw slat numbers 4 and both of slats 6 into place first. Then lay all of slats part 5 into position before screwing down.

6.

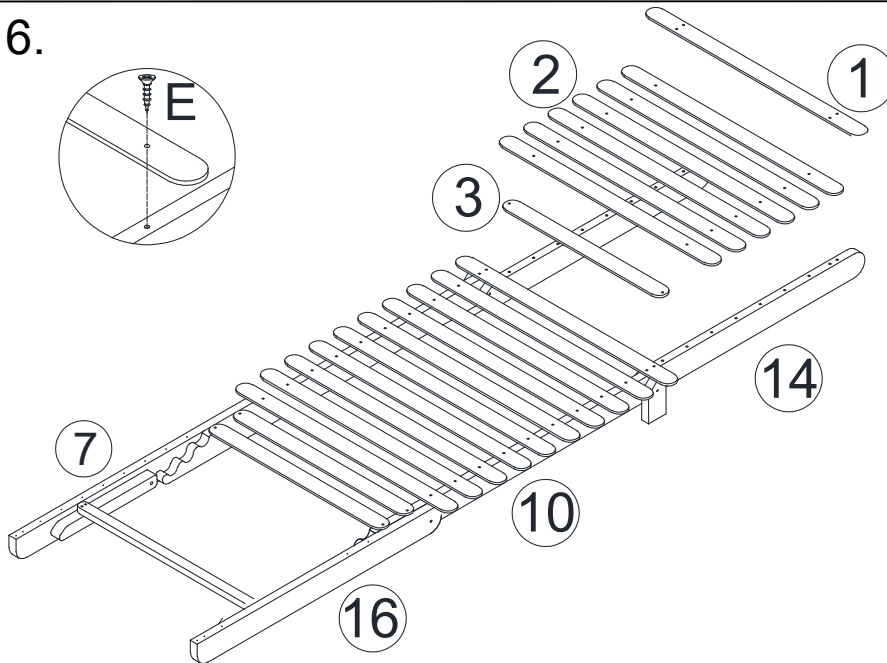

Using Fitting E, screw slat numbers 1 and 2 into place first. Then lay all of slats part 3 into position before screwing down.

7.

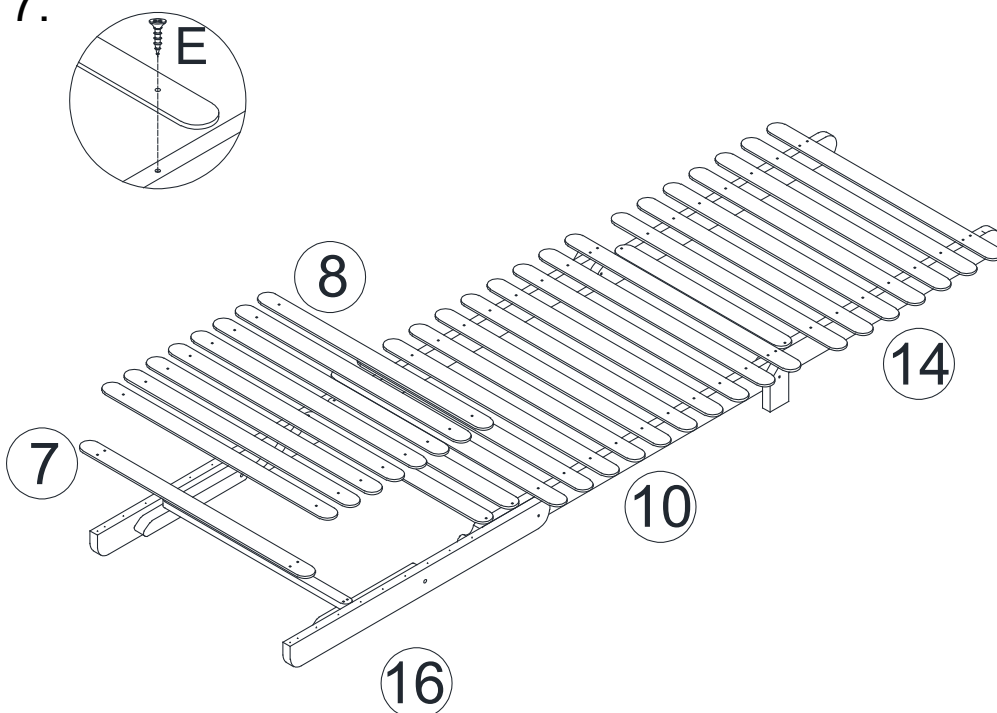

Using Fitting E, screw slat 7 and one slat 8 into place first before laying out and screwing down the remaining slats.

8.

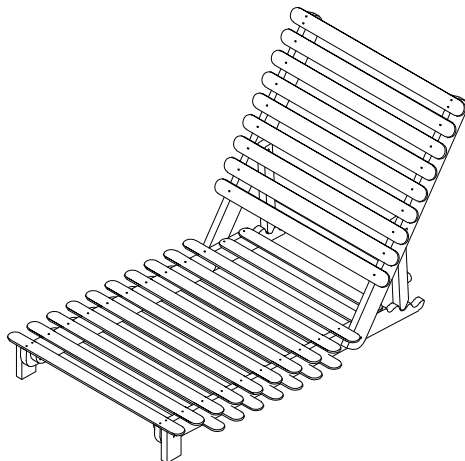
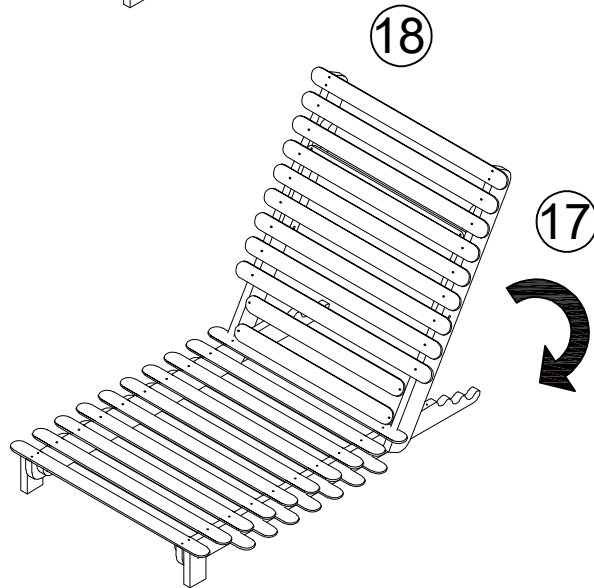
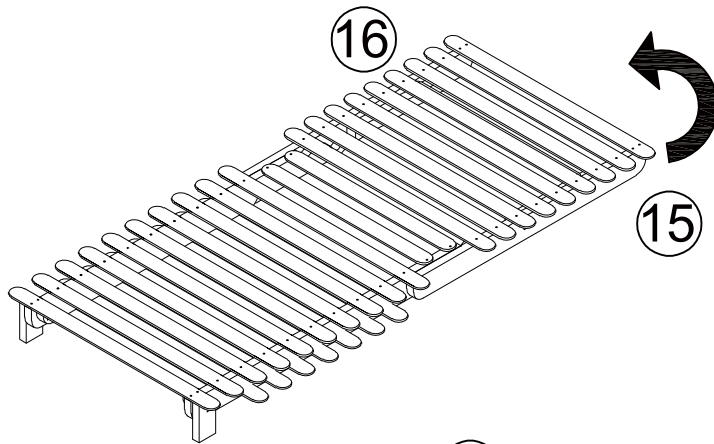
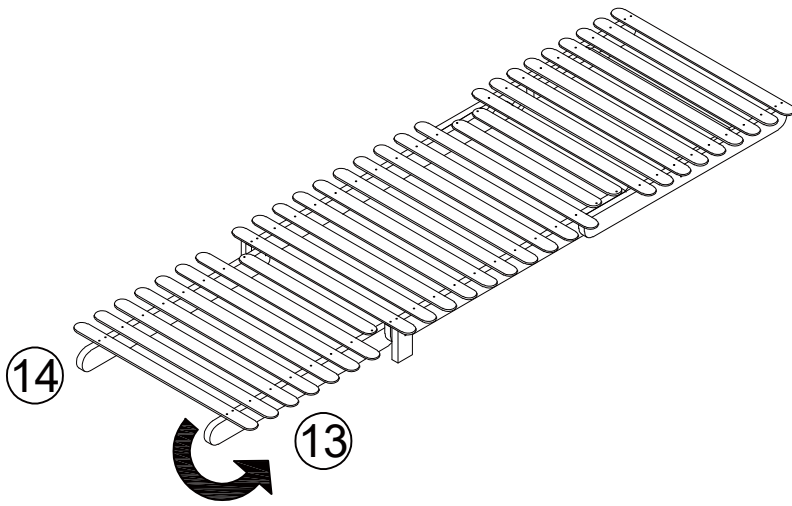

Fully tighten Fittings A,B,C & D