

# Assembly Instructions

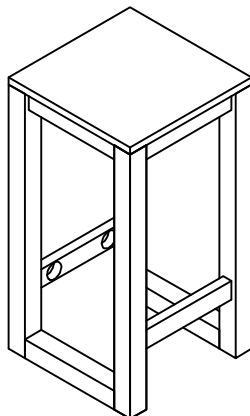

## Stool - Oak Diner

ROPO no:



**PLEASE READ THESE INSTRUCTIONS VERY CAREFULLY BEFORE YOU BEGIN, TO ENSURE THAT YOUR FUTON COMPANY PRODUCT WILL GIVE YOU MANY YEARS OF SATISFACTION**

Thank you for buying Futon Company product

We are constantly striving to improve everything we do, but very occasionally mistakes do occur.

In the unlikely event that you find any part missing please call your nearest Futon Company store and we will arrange for the despatch of an immediate replacement.

Please keep all packaging until you have checked every part and assembly of your Futon Company product is complete.

Version number: 1

Product code: STOOL DINER

Date: 20/05/15

*experts in small space living*



## Parts Checklist

Please count and check every component very carefully before you begin

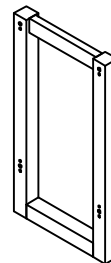

① Left and Right Legs x 2

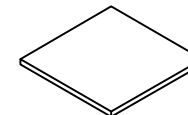

② Top Panel x 1

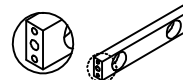

③ Bottom Rail X 2

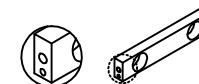

④ Top Rail X 2



## Fittings Checklist

Please count and check every component very carefully before you begin



Ⓐ Dowel x 12



Ⓑ Bolt x 8



Ⓒ Pressure Plate x 8



Ⓓ Nut x 8



Ⓔ Small Spanner x 1



Ⓕ Screw x 8

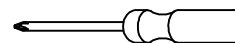

\* Cross head Screwdriver also required for assembly



# How To Assemble Your Stool

Please follow these instructions carefully

# FUTON

C O M P A N Y



# How To Use

Please read carefully

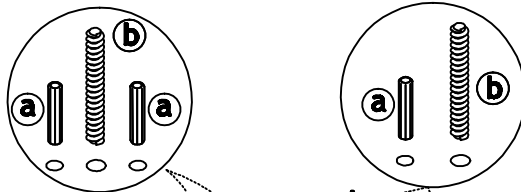

Repeat this step for both of part 1.

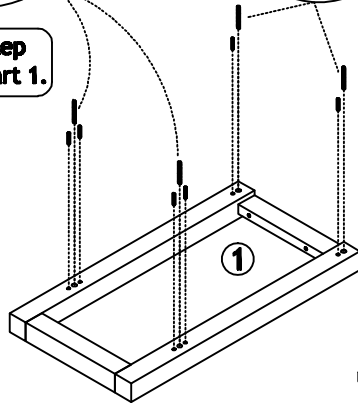

1. 2.  
3. 4.

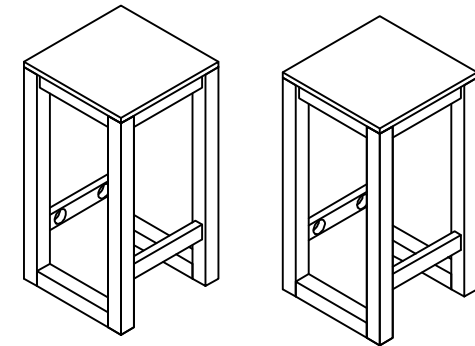
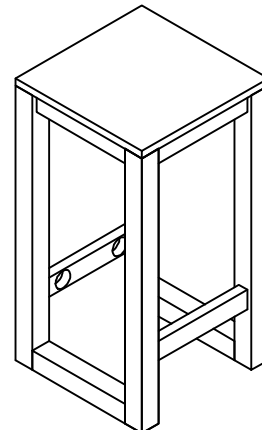
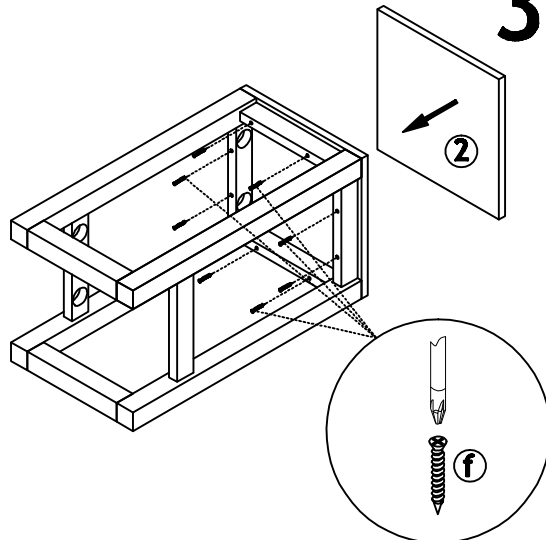
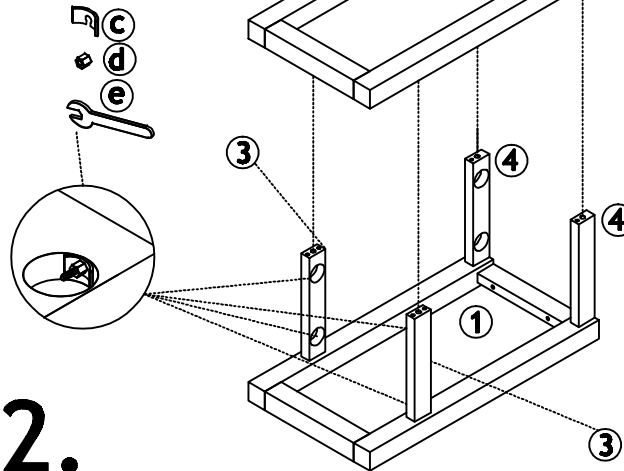

### FINISH

Timber may be selected to ensure that the visible surfaces are of a higher grade than unseen surfaces.

These unseen areas are not finished to the same standard as the visible surfaces.

### CARE

To clean your Stool, wipe with a damp cloth followed by a dry cloth.

### IMPORTANT

To ensure maximum performance from this product, we advise that you check and tighten all bolts and screws on a regular basis to avoid damage and strain to parts.

### GUARANTEE

This instruction leaflet forms part of your guarantee. Please retain it. The ROPO number along with your invoice number will need to be quoted in all correspondence with Futon Company.

Thank you for choosing Futon Company.