

BD4/5 PLAT RBW - PO12470

FUTON

C O M P A N Y

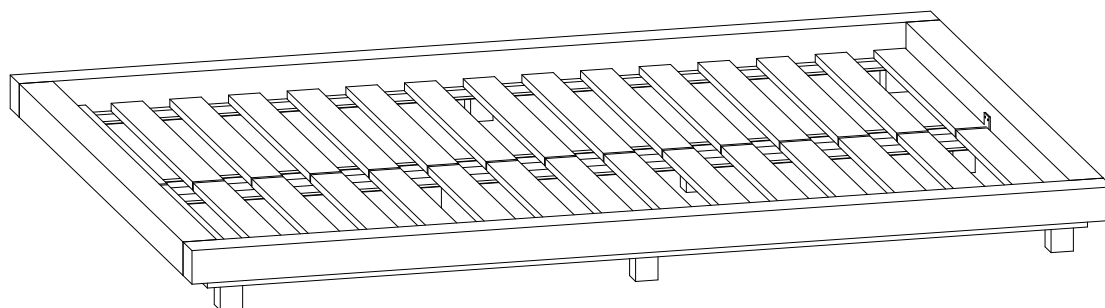



Thank you for purchasing this Futon Company product. Please read the instructions carefully before assembly.

This product takes approximately 60 minutes to assemble with two people.

You will require a cross head screwdriver to assemble this product. An electric drill may cause damage to the product and is not recommended.

Please check the pack contents before starting to assemble this product. A full checklist of components is given in this leaflet.

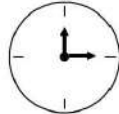
If any components are missing, please contact your nearest Futon Company store and we will arrange despatch of an immediate replacement.

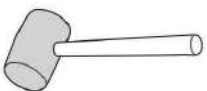
 2PERS	 60MIN	Tool Required Not Provided	
			

Fittings Checklist

A x 4



M8x70mm

B x 4



C x 4



D x 4



E x 1



F x 20

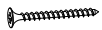

M4x55mm

G x 20



M8x30mm

H x 12

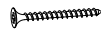

M4x35mm

I x 2

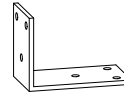

J x 12



M4x20mm

Parts Checklist

①-Side Rails x 2

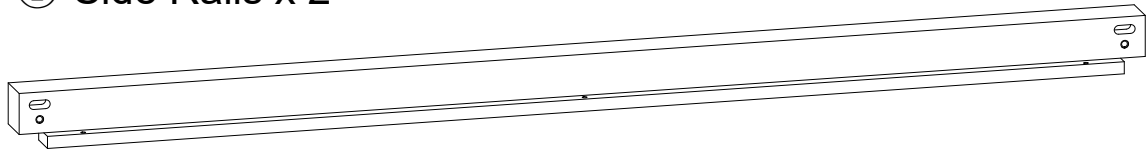

②-Cross Rails x 2

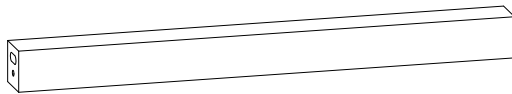

③-Feet x 10



④-Slats x 2

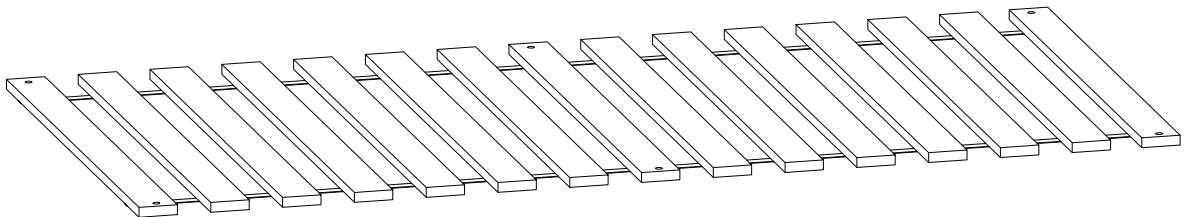

⑤-Middle Support Rail x 1

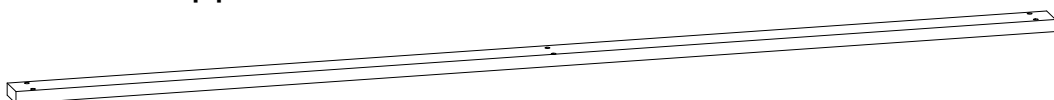

1.

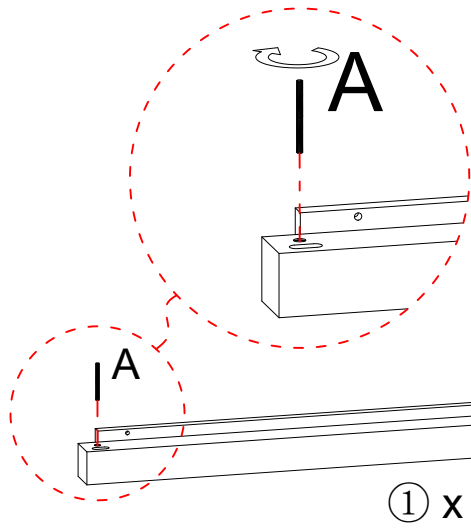

To prevent scratching: Lay the parts face down on a clean, flat, soft surface.

① x 2pcs

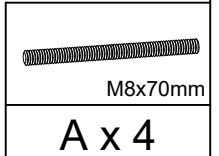

2.

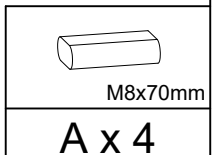
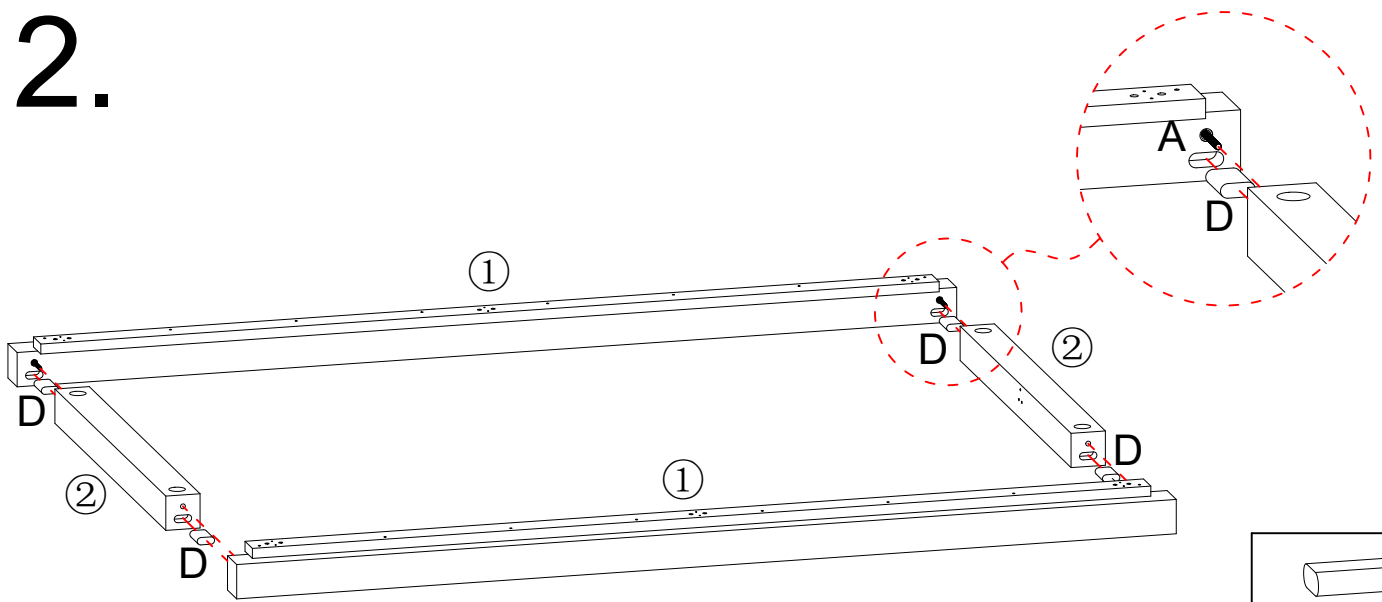

3.

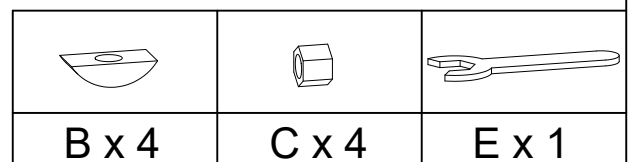
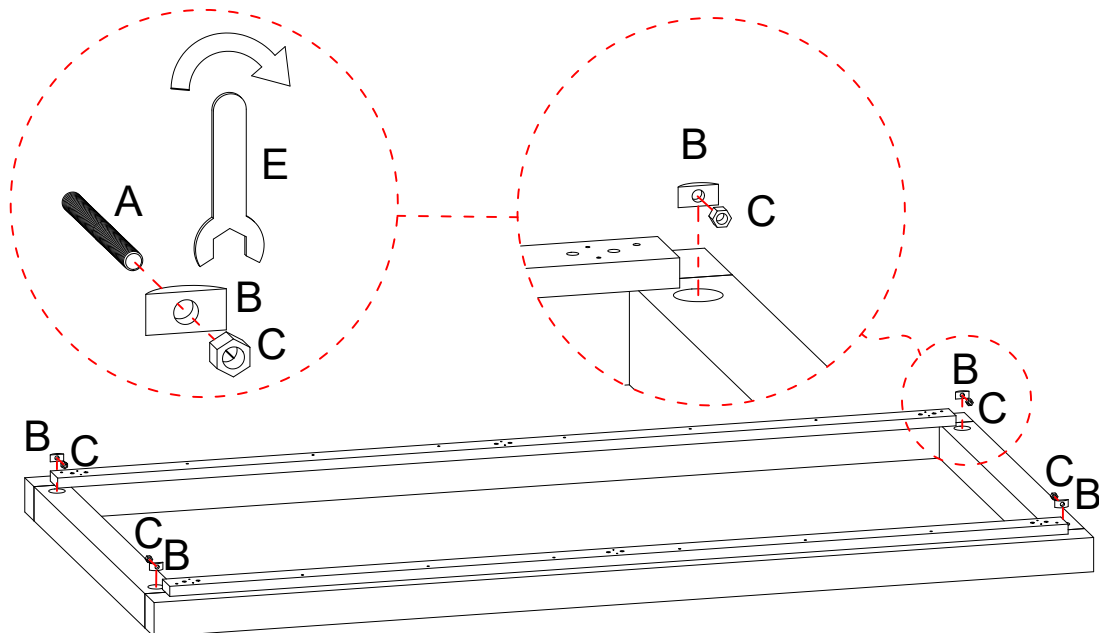

4.

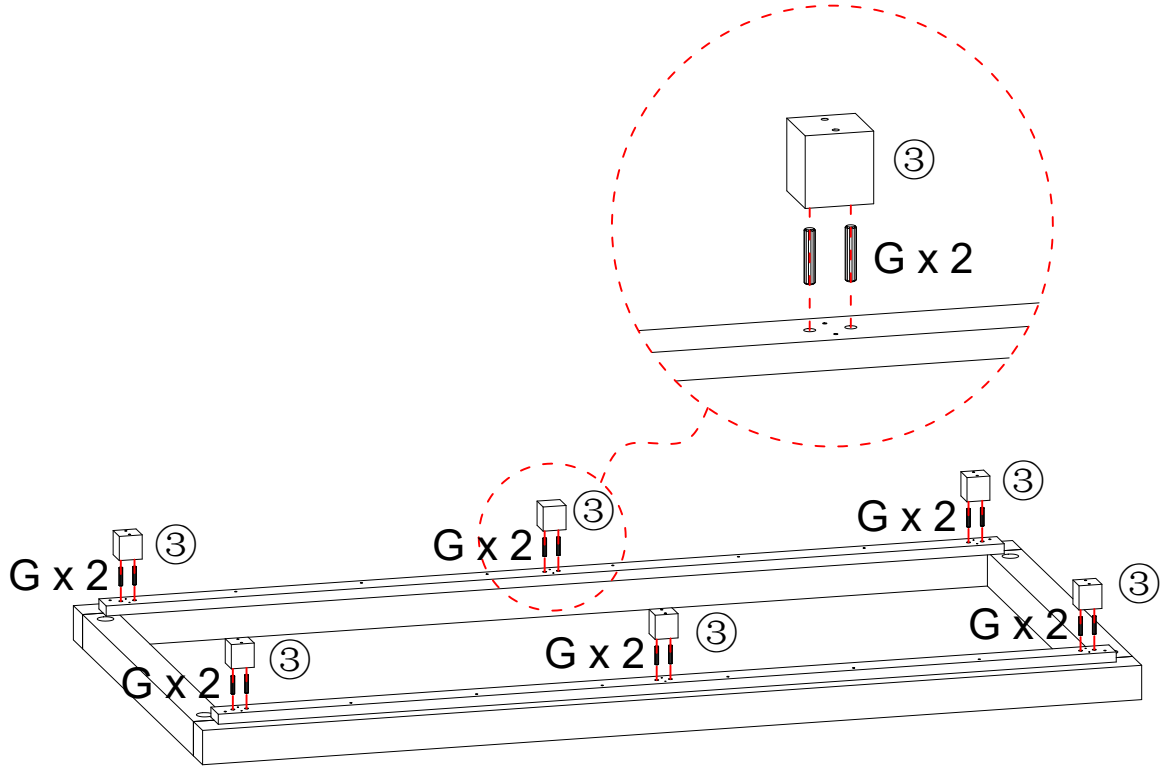

M8x30mm

$G \times 12$

5.

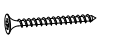
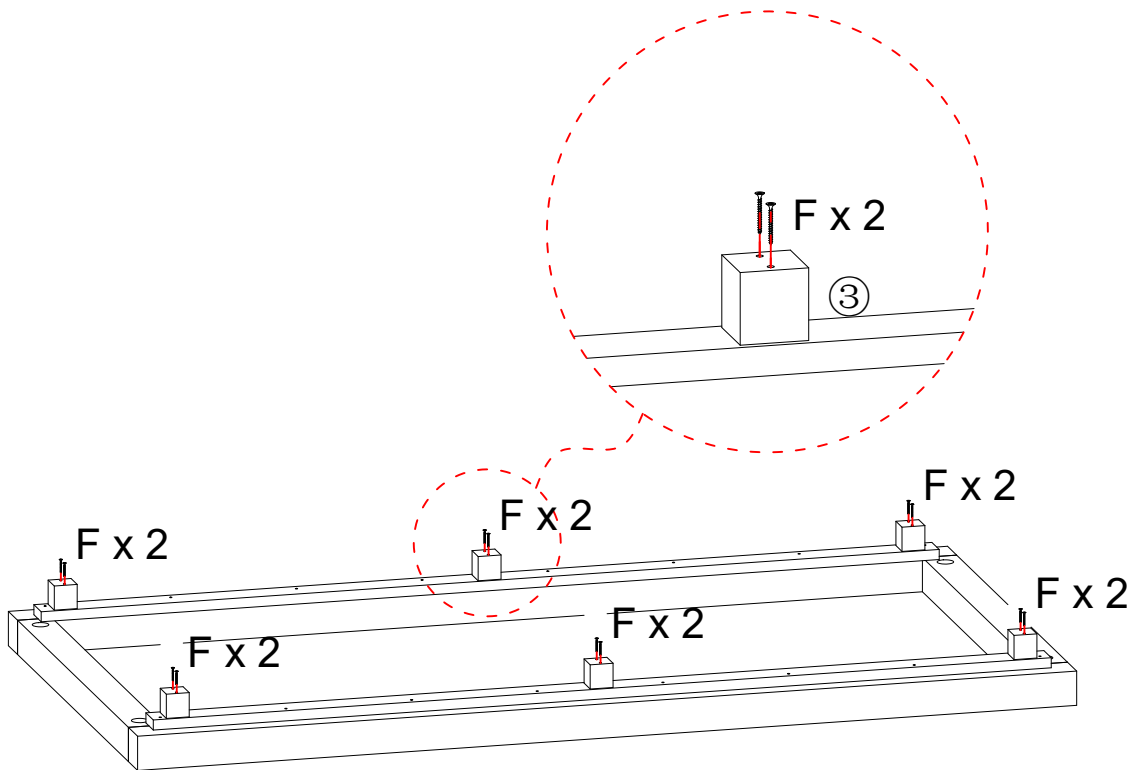

M4x55mm

$F \times 12$

6.

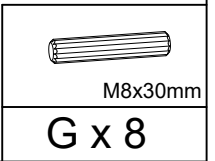
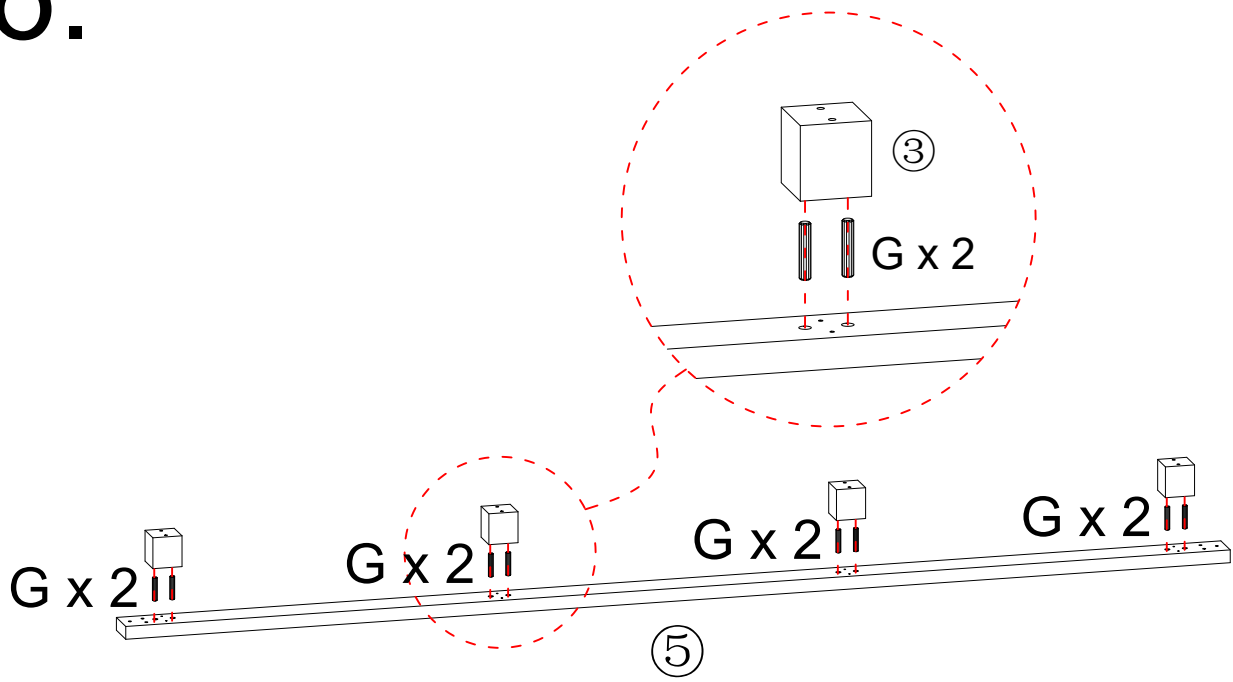

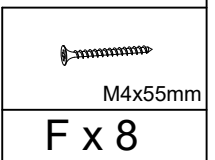
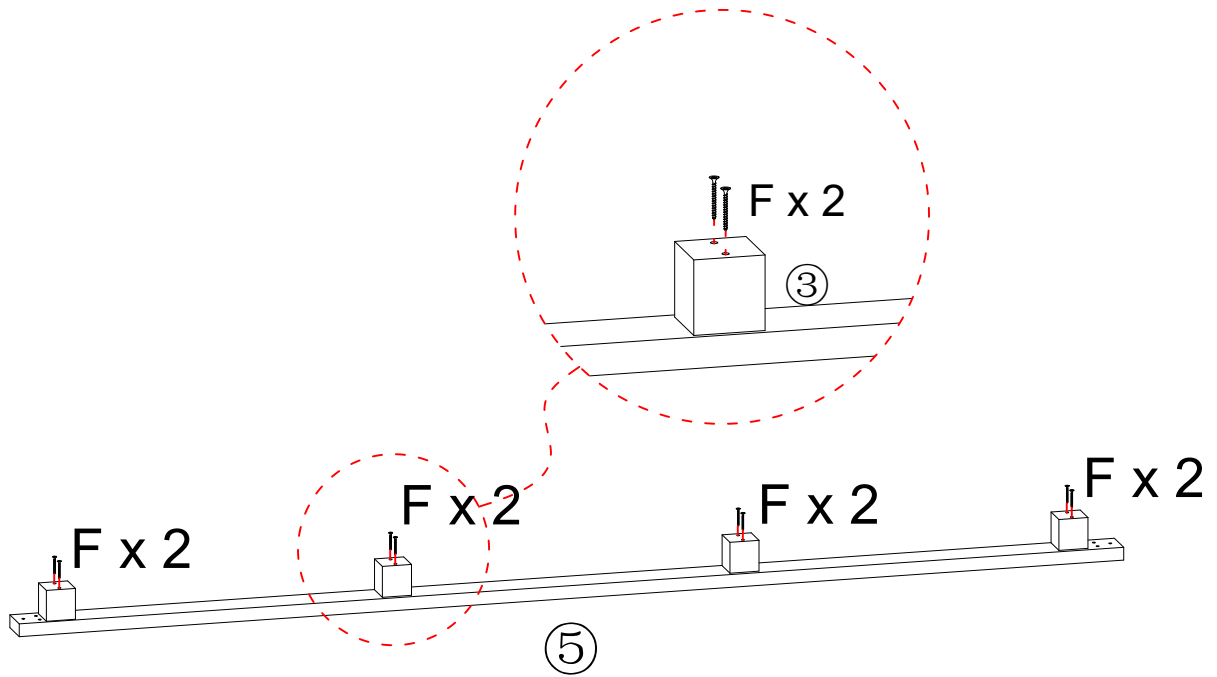

7.



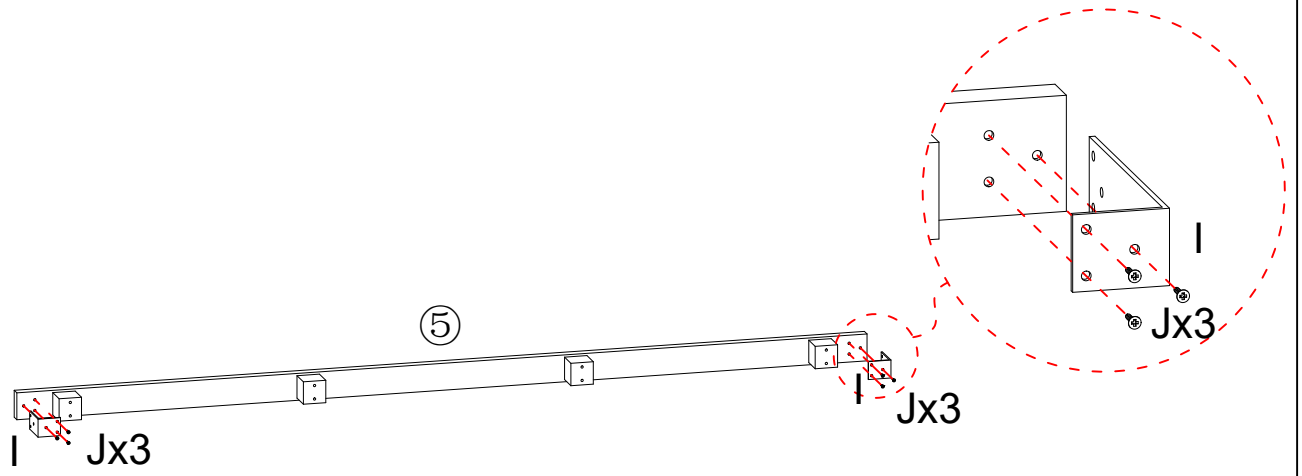

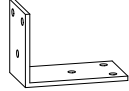
8.

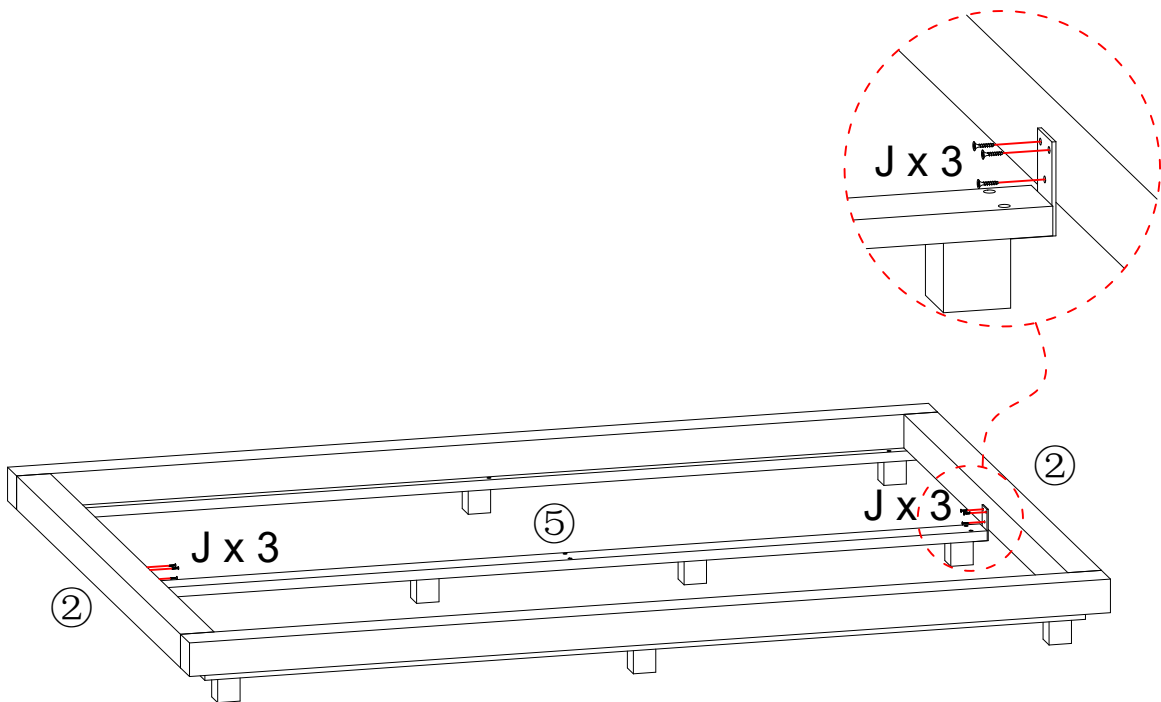

	 M4x20mm
I x 2	J x 6

9.



 M4x20mm
J x 6

